



# PROVEN PERFORMER

## On-Premises Laundry

**SWNMN1** (top loading washer),  
**SDE807** (electric dryer), **SDG809** (gas dryer)

### Top loading washer features

- Designed for durability and ease of use with push to start switch and reinforced control knobs
- Extra large capacity stainless steel tubs keep clothes looking their best
- Advanced suspension system eliminates the possibility of an unbalanced load
- Commercial quality transmission offers highest quality and durability
- Multi-cycle controls provide washing options to fit your laundry needs

### Dryer features

- Durable galvanized steel cylinder with an extra-large 198 litres of volume
- Efficient dryer heating with 5,000 kCal (gas models) and up to 4,000 Watts (electric models)
- Large, easy-to-clean lint compartment
- Reversible door
- 1913.8 sq. cm door opening is the largest in the industry, providing easy loading and unloading



EASY  
OPERATION



LARGE DOOR  
OPENING

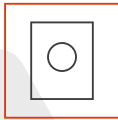

ROBUST  
DESIGN

### Controls

#### Top loading washer E-Mech control

The E-Mech control features a straightforward design that offers users simple water temperature and fabric selections.

#### Dryer E-Mech control

The E-Mech control features a straightforward design that offers users simple drying selections and uses cue lights to monitor progress through the drying cycle.



SWNMN1

SDE807, SDG809

	<b>SWNMN1</b>	<b>SDE807 (Electric) SDG809 (Gas)</b>
Type	Top Loading Washer	Single Dryer
Control	Emech	Emech
Control location	Rear	Rear
<b>Drum</b>		
Capacity kg	8	10
Cylinder volume litres	92.3	198
<b>Drum speed</b>		
Spin speed G-Force	150	n/a
Spin speed rpm	710	n/a
<b>Motor</b>		
Motor size kW	0.37	0.25
<b>Cabinet</b>		
Cylinder finish	Stainless steel	Galvanized
Colours	White	White
Door type (solid/window)	n/a	Solid
<b>Heating</b>		
Heat sources	n/a	Gas or Electric
Heating element (Electric W)	n/a	4000
<b>Connection</b>		
Gas inlet connection mm	n/a	9.5
Gas consumption BTU/Hr	n/a	60 Hz: 22,500, 50 Hz: 20,000
Exhaust outlet dia. mm	n/a	102
Exhaust airflow litres/sec	n/a	60 Hz: 105 (220), 50 Hz: 85 (180)
Water temperatures	3	n/a
<b>Operation</b>		
Cycles*	Normal, Perm Press, Special	Normal, Perm Press, Delicate, No Heat
Water consumption per cycle litres*	92.2	n/a
Water pressure bar	1.4/8.3	n/a
Cycle indicator lights	Yes	Yes
<b>Power</b>		
Electrical requirements (voltage/Hz/Ph)	240/50/1	Electric 20amp 240/50/1 Gas 10amp
<b>Transport data</b>		
Net weight kg	82	Electric/Gas 59/61
Shipping weight kg	88	Electric/Gas 64/66
Dimensions H×W×D mm	1092×650×711	1092×683×711
Packing dimensions H×W×D mm	1124×699×762	1156×737×832
<b>Agency approvals</b>		
Available agency approvals	See price sheet for applicable agency approvals by market	

\*Information provided applies to premier control offered by product class.



## Dimensions

### Top Loading Washer

	A	B	C	D	E	F	G	H	I	J
<b>SWNMN1</b>	651	745	730	1092	914	547	1025	1295	660	711

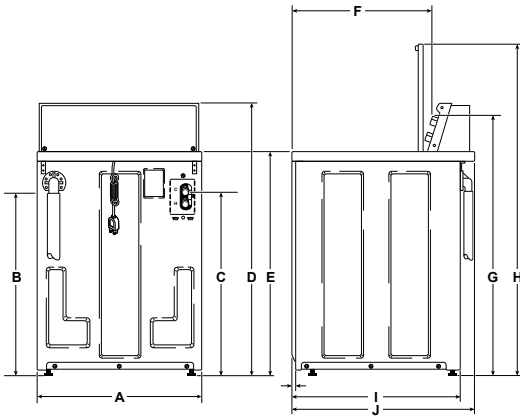

### Electric Dryer

	A	B	C	D	E	F	G	H	I	J	K	L	M
<b>SDE807</b>	589	914*	1036*	1092*	391	392*	683	102	10	711	114*	203	597

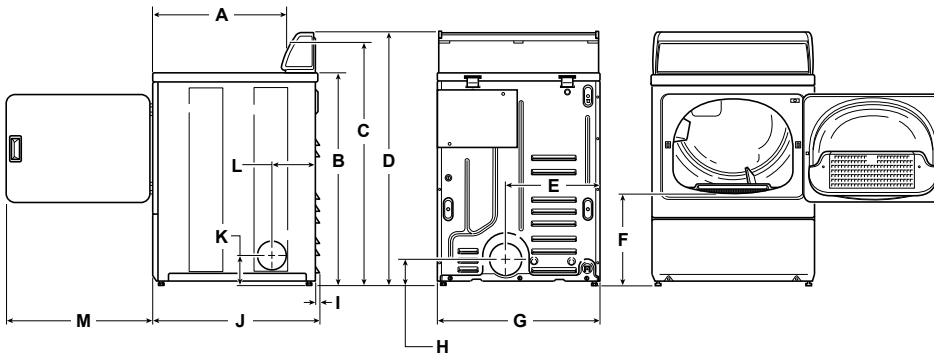

### Gas Dryer

	A	B	C	D	E	F	G	H	I	J	K	L	M	N	O
<b>SDG809</b>	589	914*	1036*	1092*	391	392*	70*	60	683	102*	10	711	114*	203	597

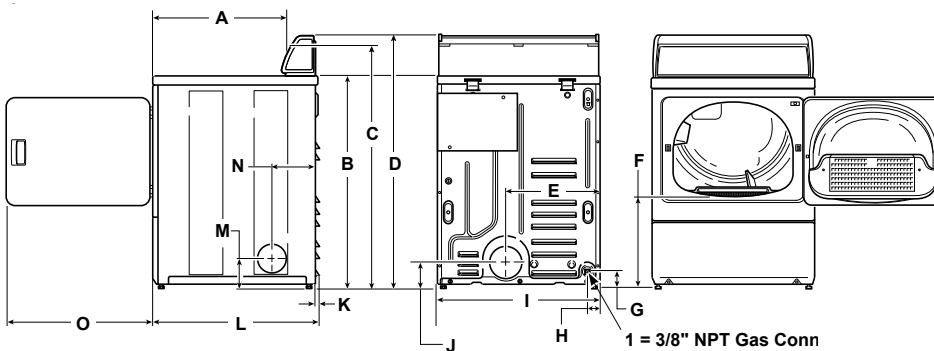

All measurements are in mm. \*With levelling legs turned into base.

NOTE: Exhaust openings are 102 mm metal ducting.

