



PROVEN PERFORMER

On-Premises Softmount Washer-Extractors SY350, SY450, SY600

Features

- Freestanding, high spin
- Stainless steel cabinet
- Stainless steel drum and tub
- QED Select – fully programmable microprocessor
- Large door opening (\varnothing 54 cm) for easy loading and unloading
- Large drain valves (2 x \varnothing 76 mm)
- Easy access to all parts
- Frequency controlled motor
- Perforated lifting ribs: more mechanical action and lower water consumption
- Eco washing programs – significantly reduces water and electricity consumption
- Soap hopper
- Liquid soap print
- USB & RS485 plug (on the back panel)

Options

- Liquid soap pumps
- QED Assist - Laundry management software
- End of cycle light and sound signalization
- Forward tilting device (pneumatic) for SY450 and SY600
- Automatic weighing system by weighing cells for measuring exact capacity of the linen
- Air operated water inlets
- Tap to take water samples
- Soap dispenser with 5 removable compartments
- Isolation for energy & noise reduction



EASY
OPERATION



ERGONOMICAL
CONSTRUCTION

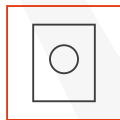

ROBUST
DESIGN

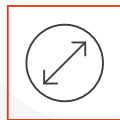

LARGE DOOR
OPENING



Control panel (QED Select)



SPEED QUEEN. WORLD NO.1 IN COMMERCIAL LAUNDRY

	SY350	SY450	SY600
INNER DRUM CAPACITY			
Volume [l]	350	450	600
Volume [kg]	35	45	60
Depth [mm]	535	690	715
Diameter [mm]	914	914	1035
MOTOR			
Power [kW]	4	7.5	7.5
DRUM SPEED			
Wash speed (max) [rpm]	45		42
Extraction speed (max) [rpm]	839		788
G-factor	360	360	360
PROGRAMMER			
Type of control	QED Select	QED Select	QED Select
CABINET			
Stainless steel	Yes	Yes	Yes
Door Opening [mm]	540	540	540
Door Opening angle [mm]	178	178	178
HEATING			
100% Hot Water [°C]	90	90	90
100% Electrical [kW]	24	36	54
Steam High Pressure [bar]	3-8	3-8	3-8
CONNECTION			
Water Inlet [in]	3x1"	3x1"	3x1"
Steam Inlet [in]	1x3/4"	1x3/4"	1x3/4"
Drain Diameter [in]	2x3"	2x3"	2x3"
Drain valve outer [mm]	2x76	2x76	2x76
Flow amount with drain valve [l/min]	2x210	2x210	2x210
POWER			
Electrical requirements [V/ Hz]	3x200-240V /50-60Hz 3x380-415V 50-60Hz 3x 440-480V 50/60Hz	3x200-240V /50-60Hz 3x380-415V 50-60Hz 3x 440-480V 50/60Hz	3x200-240V /50-60Hz 3x380-415V 50-60Hz 3x 440-480V 50/60Hz
Heating element [kW]	24	36	54
TILTING			
Forward tilting	n/a	Option	Option
TRANSPORT DATA			
Net Weight [kg]	1010	1350	1500
Net Weight (w/tilting) [kg]	n/a	1390	1540
Shipping Weight [kg]	1170	1490	1640
Shipping Weight (w/tilting) [kg]	n/a	1530	1680
Crate packing volume [m³]	4.45	5.15	5.15
Crate packing volume (w/ tilting) [m³]	n/a	5.26	5.26
DIMENSIONS			
Dimensions HxWxD [mm]	1925x1315x1270	1925x1315x1502	1925x1315x1502
Packaging dimension HxWxD [mm]	2125x1425x1470	2125x1425x1700	2125x1425x1700

Dimensions

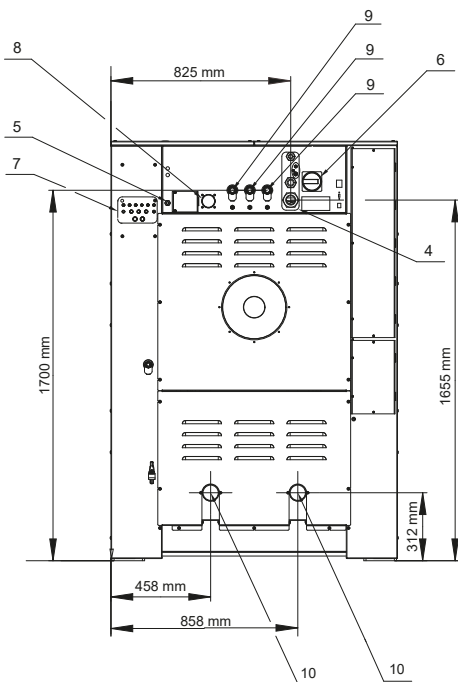
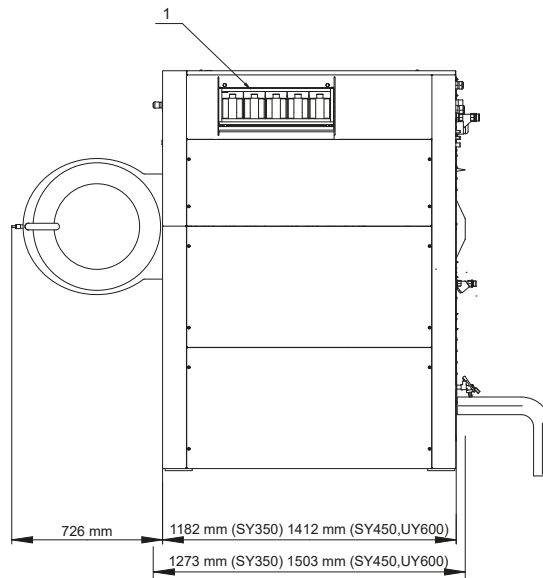
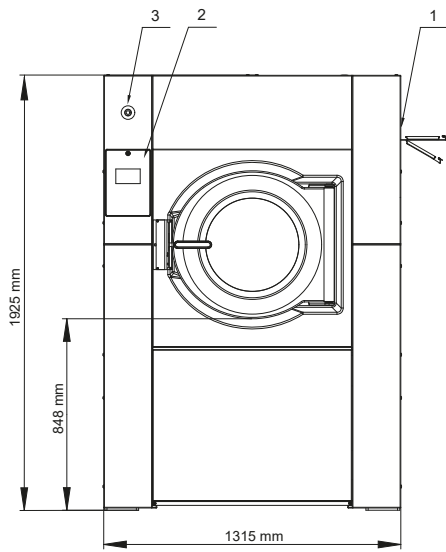

- 1** Soap hopper
- 2** Keyboard
- 3** Emergency stop
- 4** Electrical connection
- 5** Electrical connection t liquid soap
- 6** Main switch
- 7** Liquid soap pump connections
- 8** Air vent tub
- 9** Water connection
- 10** Drain valve
- 11** Water sample tap



Alliance Laundry Systems
Worldwide Headquarters
PO Box 990, Shepard Street, Ripon, WI 54971 USA
www.speedqueencommercial.com

