



PROVEN PERFORMER

Vended Laundry

SSENXA (stack dryer - electric),
SSGNXA (stack dryer - gas)

Dryer features

- Durable galvanized steel cylinder with an extra-large 198 litres of volume
- Efficient dryer heating with 6,300 kCal (gas models) and up to 4,000 Watts (electric models)
- Extended tumble helps eliminate wrinkling
- Quiet, efficient blower system uses a superior airflow of 5100 litres per minute
- 1913.8 sq. cm door opening is the largest in the industry, providing easy loading and unloading for customers

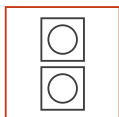

STACKABLE UNIT



STANDARD STAINLESS STEEL DRUM

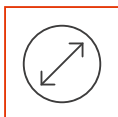

LARGE DOOR OPENING



LOW WATER CONSUMPTION



LOW ENERGY CONSUMPTION



COMPACT DESIGN

Controls

Quantum™ Gold

In addition to its network capabilities and off-site management features, Quantum™ Gold offers additional owner and customer benefits such as PC programming and machine audit capabilities, as well as time-of-day pricing, a "lucky cycle" for loyal customers and the ability to interface with the store owner's payment systems. Cycle modifier keys create additional profit opportunities for store owners.



SSENXA, SSGNXA

	SSENXA (Electric) SSGNXA (Gas)
Type	Stack Dryer/Dryer
Control	Quantum
Control location	Front
Drum	
Capacity kg	2 x 10
Cylinder volume litres	198
Drum speed	
Spin speed G-Force	n/a
Spin speed rpm	n/a
Motor	
Motor size kW	0.25
Cabinet	
Cylinder finish	Galvanized
Colours	White
Door type (solid/window)	Window
Heating	
Heat sources	Gas or Electric
Heating element (Electric W)	4000
Connection	
Gas inlet connection mm	9.5
Gas consumption BTU/Hr	25,000
Exhaust outlet dia. mm	102
Exhaust airflow litres/sec	60 Hz: 105 (220), 50 Hz: 85 (180)
Water temperatures	n/a
Operation	
Cycles*	High, Medium, Low, Delicates, No Heat
Water consumption per cycle litres*	n/a
Water pressure bar	n/a
Cycle indicator lights	Yes
Power	
Electrical requirements (voltage/Hz/Ph)	Electric 20amp 240/50/1 Gas 10amp
Transport data	
Net weight kg	Electric/Gas 120/125
Shipping weight kg	Electric/Gas 127/132
Dimensions H×W×D mm	1986×683×711
Packing dimensions H×W×D mm	2032×737×832
Agency approvals	
Available agency approvals	See price sheet for applicable agency approvals by market

*Information provided applies to premier control offered by product class.



Dimensions

Stack Dryer/Dryer – electric

	A	B	C	D	E	F	G	H	I	J	K	L	M
SSENXA	597	213	711	11	203	1184	1986*	102*	114*	683	391	392*	994*

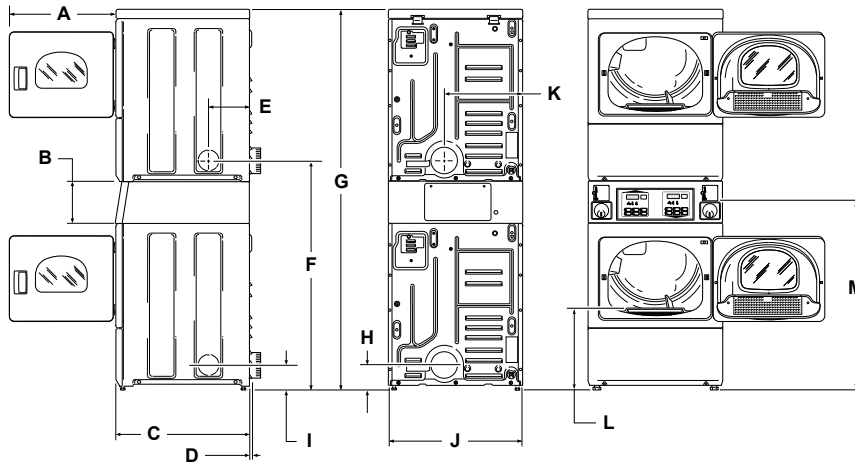

Stack Dryer/Dryer – gas

	A	B	C	D	E	F	G	H	I	J	K	L	M	N	O	P
SSGNXA	597	213	711	11	203	1184	1986*	102*	114*	683	60	391	1140*	70*	392*	994*

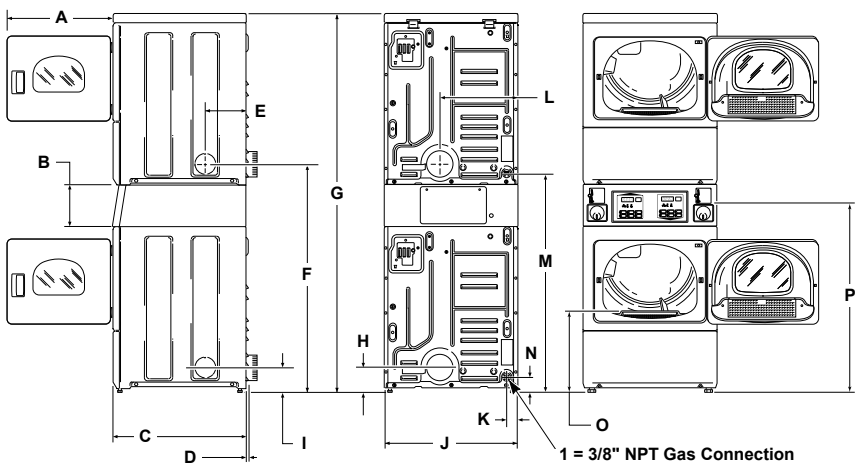

All measurements are in mm. *With levelling legs turned into base.

NOTE: Exhaust openings are 102 mm metal ducting. Gas models cannot be vented out left side of cabinet because of burner housing.

